



AUTOMATION FOR TANNERIES AND INDUSTRIES



1969 - 2019



CAVALLETTI PNEUMATICI PER PELLI CONVERTIBILI IN TAVOLA



PNEUMATIC HORSES FOR LEATHERS CONVERTIBLE INTO TABLE



CABALLETES NEUMÁTICOS PARA PIELES CONVERTIBLES EN MESA

## GENERALITA'

I nostri cavalletti **agevolano il deposito e/o la rifilatura manuale delle pelli** e sono costituiti da una struttura meccanica, un sistema pneumatico per l'apertura e la chiusura delle fiancate e da un telo superiore per appoggio materiale. Sono dotati di ruote per lo spostamento, serbatoio per l'aria (oppure, su richiesta, compressore da 25 litri) e leva manuale per **fermare l'apertura/chiusura delle fiancate secondo la propria esigenza**.

### Versioni disponibili:

- telo superiore con angoli
- telo superiore con angoli smussati

### Dimensioni:

Di seguito sono indicate le dimensioni standard, ma **siamo in grado di fornire cavalletti SU MISURA**, costruiti secondo le esigenze del Cliente, sempre rispettando le caratteristiche tecniche di costruzione.

CAVALLETTO MOD.	larghezza utile mm (a)	lunghezza mm (d)	altezza aperto mm (b)	altezza chiuso mm (c)	portata kg
CP1	1500	2400	850	1450	600
CP1-A	1800	1800	795	1245	700
CP1-R	2000	1600	795	1245	800
CP2	2400	2400	840	1450	850
CP3	3000	2600	900	1600	900

## INTRODUCTION

Our horses **make easier the deposit and/or leather manual trimming**.

They consist of a mechanical structure, a pneumatic system for sides opening/closing and an upper cloth for the placing of goods. They are equipped with wheels for moving, tank for the air (or a 25 liters compressor, on request) and manual lever to **stop sides opening/closing according to the need**.

### Available versions:

- upper cloth with corners
- upper cloth with rounded edges

### Sizes:

Standard sizes are indicated here under, but **we can supply CUSTOMIZED horses**, entirely projected according to Customer's exigency, always respecting the construction technical features.

HORSE MOD.	useful width mm (a)	length mm (d)	height when open mm (b)	height when closed mm (c)	capacity kg
CP1	1500	2400	850	1450	600
CP1-A	1800	1800	795	1245	700
CP1-R	2000	1600	795	1245	800
CP2	2400	2400	840	1450	850
CP3	3000	2600	900	1600	900

## INTRODUCCIÓN

Nuestros caballetes **facilitan el depósito y/o el recorte manual de las pieles**.

Se componen de una estructura mecánica, un sistema neumático para abrir y cerrar los lados y una lona superior para apoyar el material. Están provistos de ruedas para el desplazamiento, tanque para el aire (o, sobre pedido, compresor de 25 litros) y palanca manual para **parar la apertura/cierre de los lados según exigencia**.

### Versiones disponibles:

- lona superior con ángulos
- lona superior con ángulos redondeados

### Medidas:

Abajo están indicadas las medidas estándar, pero **podemos proveer caballetes A MEDIDA**, construidos según las exigencias del Cliente, siempre respetando las características técnicas de construcción.

CABALLETE MOD.	ancho útil mm (a)	longitud mm (d)	altura abierto mm (b)	altura cerrado mm (c)	capacidad kg
CP1	1500	2400	850	1450	600
CP1-A	1800	1800	795	1245	700
CP1-R	2000	1600	795	1245	800
CP2	2400	2400	840	1450	850
CP3	3000	2600	900	1600	900

# ORSES - CABALLETES NEUMATICOS

 VERSIONE STANDARD - ESEMPI

 STANDARD MODEL - EXAMPLES

 MODELO ESTÁNDAR - EJEMPLOS



 VERSIONE CON ANGOLI ARROTONDATI - ESEMPI

 MODEL WITH ROUNDED EDGES - EXAMPLES

 MODELO CON ÁNGULOS REDONDEADOS - EJEMPLOS

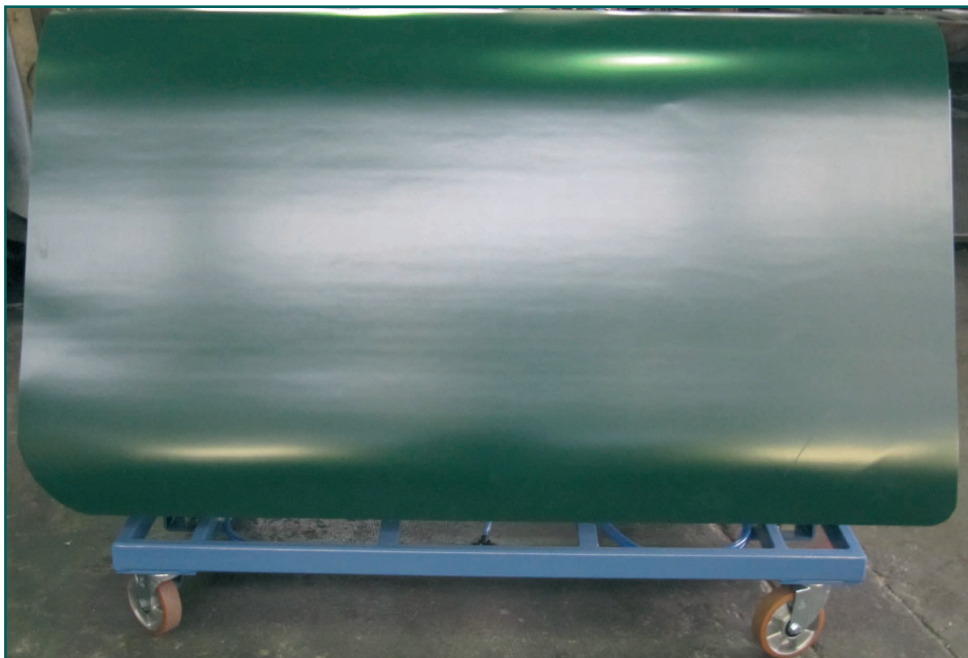

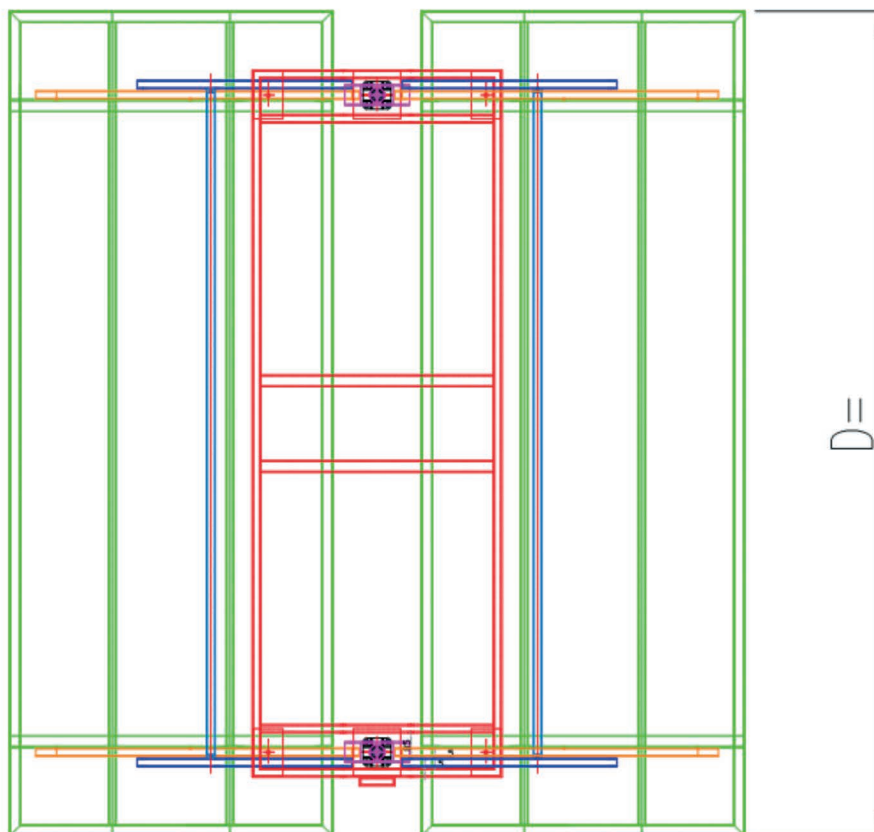
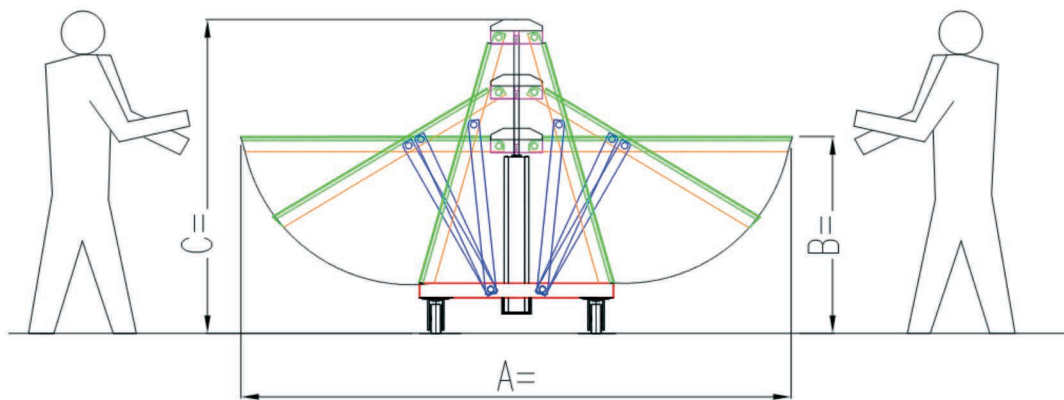

**OFF. MECCANICA M.M. s.n.c.** dei f.lli Meggiolaro  
36050 MONTORSO VIC.NO (VI) ITALY - Via Valchiampo, 48  
Tel. +39 0444 484101 - Fax +39 0444 685486  
E-mail: [info@mm-meggiolaro.it](mailto:info@mm-meggiolaro.it)  
[www.mm-meggiolaro.com](http://www.mm-meggiolaro.com)